



SF400M (BF)

FULL CELL LINE



Peimar monocrystalline solar panels, produced using a combination of innovative production processes and advanced engineering techniques, provide customers with maximum output and super high performance.

This allows fewer panels to be used to generate more energy, ideal if space is restricted or environmental conditions are challenging. Modern design, using matching black cells and frames and a very long lifespan ensure this monocrystalline are a great option.

30 YEAR LINEAR POWER WARRANTY
30 YEAR PRODUCT WARRANTY



PERC TECHNOLOGY



MODULE FIRE PERFORMANCE: **CLASS 1**



ANTI-REFLECTIVE GLASS



QBE INSURANCE
Product Liability Insurance QBE

Cells



66 CELLS
MONO gBB M6 | PERC

166 x 166 mm / 6.54 x 6.54"

Frame



COMPACT AND STURDY | 40 mm

ANCHORABLE ALSO ON
THE SHORT SIDE ⁽³⁾

Electrical Characteristics (STC) ⁽¹⁾

SF400M (BF)

| | |
|--|----------|
| Nominal Output (Pmax) ⁽²⁾ | 400 W |
| Sorting Tolerance | 0/+5 W |
| Voltage at Pmax (Vmp) | 38.00 V |
| Current at Pmax (Imp) | 10.53 A |
| Open Circuit Voltage (Voc) ⁽²⁾ | 45.60 V |
| Short Circuit Current (Isc) ⁽²⁾ | 11.16 A |
| Maximum System Voltage | 1500 V |
| Maximum Series Fuse Rating | 20 A |
| Module Efficiency | 20.09% |
| Protection class against electric shock | Class II |

Mechanical Characteristics

| | |
|---------------------------|---|
| Solar Cells | 66 (6 x 11) M6 monocrystalline PERC |
| Solar Cells Size | 166 x 166 mm / 6.54 x 6.54" |
| Front Cover | 3.2 mm / 0.13" thick, low iron tempered glass |
| Back Cover | TPT (Tedlar-PET-Tedlar) |
| Encapsulant | EVA (Ethylene vinyl acetate) |
| Frame | Anodized aluminium alloy, double wall |
| Frame finishing | Black |
| Backsheet finishing | White |
| Diodes | 3 Bypass diodes serviceable |
| Junction Box | IP67 rated |
| Connector | MC4 or compatible connector |
| Cables Length | 1100 mm / 43.31" |
| Cables Section | 4.0 mm ² / 0.006 in ² |
| Dimensions | 1900 x 1048 x 40 mm / 74.80 x 41.25 x 1.57" |
| Weight | 22 kg / 48.5 lbs |
| Max Load (Test Load) - SF | 5400 Pa - 15 ⁽⁶⁾ |

Temperature Characteristics

| | |
|---------------------------------|----------------|
| NMOT ⁽³⁾ | 45±2 °C |
| Temperature Coefficient of Pmax | -0.37 %/°C |
| Temperature Coefficient of Voc | -0.28 %/°C |
| Temperature Coefficient of Isc | 0.042 %/°C |
| Operating Temperature | -40 °C - +85°C |

Packaging ⁽⁴⁾

| | |
|-------------------|--|
| Pallet dimensions | 1950 x 1200 x 1210 mm / 76.77 x 47.24 x 47.64" |
| Pieces per pallet | 27 |
| Weight | 610 Kg / 1344 lbs |

Certifications

| | |
|-------------------------|--|
| Fire Resistance Rating | Class of reaction to fire 1 (UNI g177) |
| Fire Performance Rating | Type 1 (UL 1703-3rd Edition) |

Dimensions

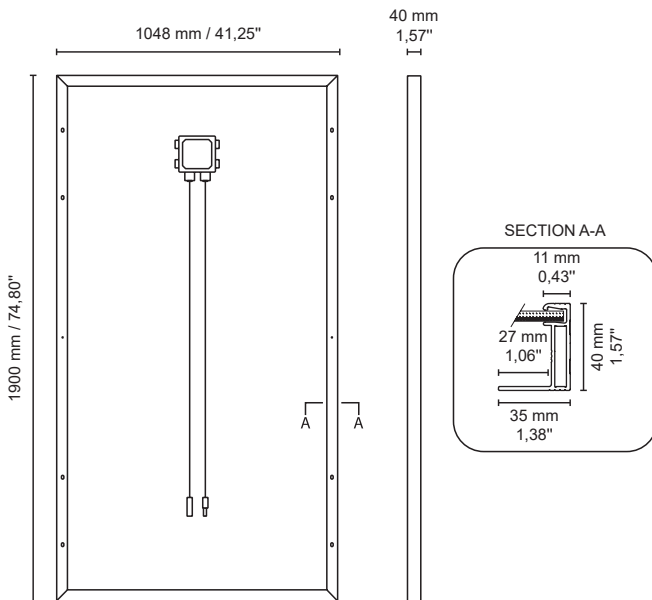

Current/Voltage Characteristics

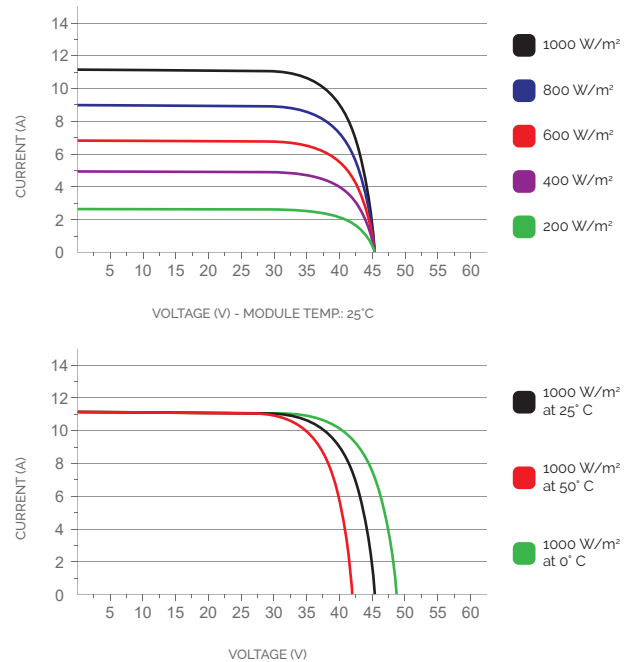

1. STC: (Standard Test Condition) Irradiance 1000W/m², Module Temperature 25°C, Air Mass 1.5

2. Pmax, Voc, Isc measurement tolerance: ±3%

3. NMOT: Nominal Module Operating Temperature. Irradiance 800W/m², Air 20°C, Wind speed 1m/s

4. Pallets can be stacked up to two

5. Consult the installation manual for the relative mounting configurations